

NOTES:

1. SUBSTRATE: N-BK7
2. COATING
S1 & S2: R(ABS) < 0.25% @ 532nm

3. EDGES: FINE GRIND

4. CENTERING: <5 ARCMIN

5. ASPHERE FIGURE ERROR @ 632.8nm: 1.6λ RMS and 6λ PV

6. ASPHERIC SURFACE DESCRIBED BY (REF. COEFFICIENT TABLE)

$$Z_{ASPH}(Y) = \frac{(\frac{1}{RADIUS}) * Y^2}{1 + \sqrt{1 - (1+k) * (\frac{1}{RADIUS})^2 * Y^2}} + D * Y^2 + E * Y^4 + F * Y^6 + G * Y^8 + H * Y^{10} + J * Y^{12} + L * Y^{14}$$

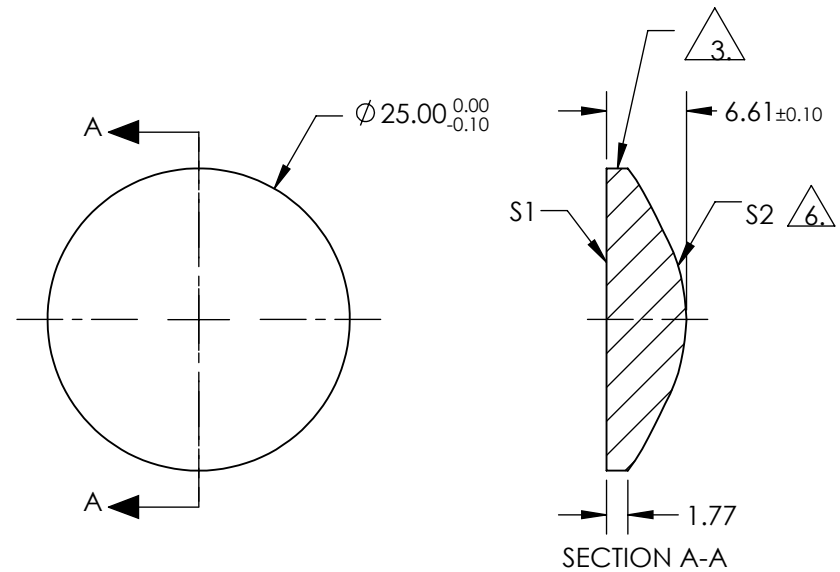

COEFFICIENT TABLE 6.	
COEFFICIENT	S1
(1/RADIUS)	7.700008E-02
k	-2.308797E+00
D	0.000000E+00
E	0.000000E+00
F	0.000000E+00
G	0.000000E+00
H	0.000000E+00
J	0.000000E+00
L	0.000000E+00

**FOR INFORMATION ONLY:
DO NOT MANUFACTURE
PARTS TO THIS DRAWING**

SPECIFICATIONS SUBJECT TO CHANGE WITHOUT NOTICE DIMENSIONS ARE FOR REFERENCE ONLY

REV. A	S1	S2	EFL @ 532.8μm	25.00	Edmund Optics®	
SHAPE	PLANO	CONVEX	BFL @ 532.8μm	N/A	25mm DIA. X 25mm FL, 532nm V-COAT, Hyperbolic Aspheric Lens	
RADIUS	INFINITY	25.97	THIRD ANGLE PROJECTION			
SURFACE QUALITY	40-20	40-20	ALL DIMS IN mm		DWG NO	89431
CLEAR APERTURE	Ø22.50	Ø22.50				SHEET 1 OF 1
BEVEL MAX	PROTECTIVE AS NEEDED	PROTECTIVE AS NEEDED				