



Hawkeye Detector Datasheet

Standard, High Gain & High Frequency Models

Hawkeye Detector

The Hawkeye Detector series has been designed to complement the Global Laser Premier, Acculase and Varilite ranges as well as being compatible with the entire range of modulatable and non-modulatable lasers. For each Hawkeye product there is a choice between a regular or enhanced sensitivity model. The enhanced version offers better sensitivity in the blue and green spectrum.

The Ø15mm module utilizes an effective amplification system, giving a high signal to noise ratio over a wide bandwidth. This ensures excellent performance even in high ambient light conditions, making the Hawkeye ideal for use in a wide range of both indoor and outdoor applications.

Independent AC & DC outputs provide options for modulation and linear amplitude monitoring to fulfil a vast range of requirements for a variety of purposes.

The integrated optic collects large spot diameters, useful in long distance targetting applications.

A removable front sleeve revealing a M12 threaded front provides easy mounting options of both clamping or a bulkhead fixing arrangement to further enhance the detector's extensive capabilities.



Detector Options

Available in three versions each with AC and DC outputs for higher and lower frequency signals, there is a Hawkeye to suit a wide range of applications and requirements.

Standard Hawkeye

Provides 1V/mW at 650nm for AC & DC outputs allowing quick and easy recognition of the characteristics of the detected signal. DC frequency response is up to 1kHz (f_{reject}) and AC response is from 1kHz to 680kHz (f_{limit}).

High Gain Hawkeye

Provides an amplified 1Vp-p/0.1mW (10Vp-p/mW) for the AC output making it ideal for lower power laser applications, the DC output provides 1V/mW. The DC frequency response is up to 1kHz (f_{reject}) and AC response continues from 1kHz to >100kHz (f_{limit}). To achieve a 10Vp-p signal output on High Gain models, the unit must have a supply voltage of atleast 10Vdc

High Frequency Hawkeye

Has a AC/DC output frequency response crossover (f_{reject}) raised to 10kHz for applications where a higher DC coupled frequency response is preferred, AC output response continues from 10kHz to 660kHz (f_{limit}). Both AC and DC outputs provide 1V/mW at 650nm for recognition of detected signal characteristics.

Typical Frequency Response

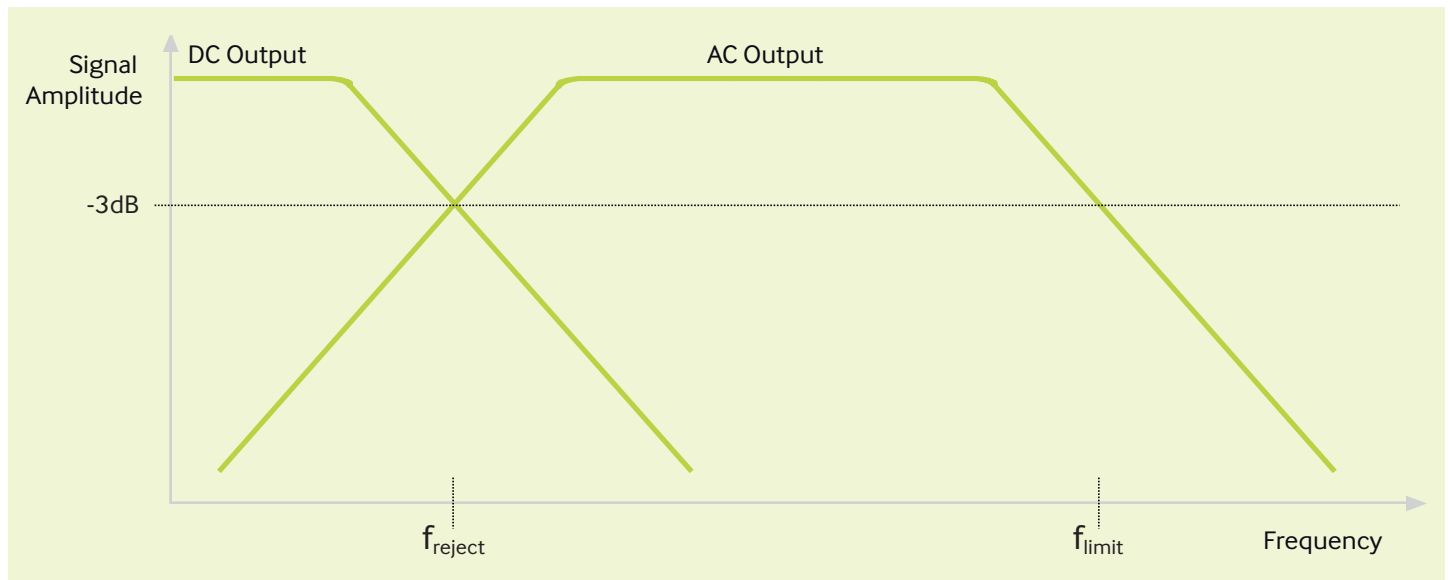

AC Output

The AC output provides an output for higher frequency modulated signals.

The Standard and High Frequency models have an output sensitivity of 1Vp-p output for every 1mW of detected laser power. The output is DC coupled with a 2.5V offset about which the output is centred.

The High Gain model has a sensitivity of 1Vp-p for every 0.1mW of detected laser power (10Vp-p/mW maximum). For the maximum output of 10V p-p, a supply voltage of at least 10V is required. The output is DC coupled and with a 10V supply voltage there is a 5V offset about which the output is centred. With supply voltages between 5 & 10V the offset is proportional.

DC Output

The DC output provides a DC output for CW and lower frequency modulation. The sensitivity for each of the models is 1V/mW at 650nm, please see the relative sensitivity chart below for alternative wavelength characteristics.

Output sensitivity for both outputs is at 650nm, please see the relative sensitivity chart below for alternative wavelength characteristics.

Relative Sensitivity

The profiles below show the sensitivity of the Hawkeye Detector and different wavelengths.

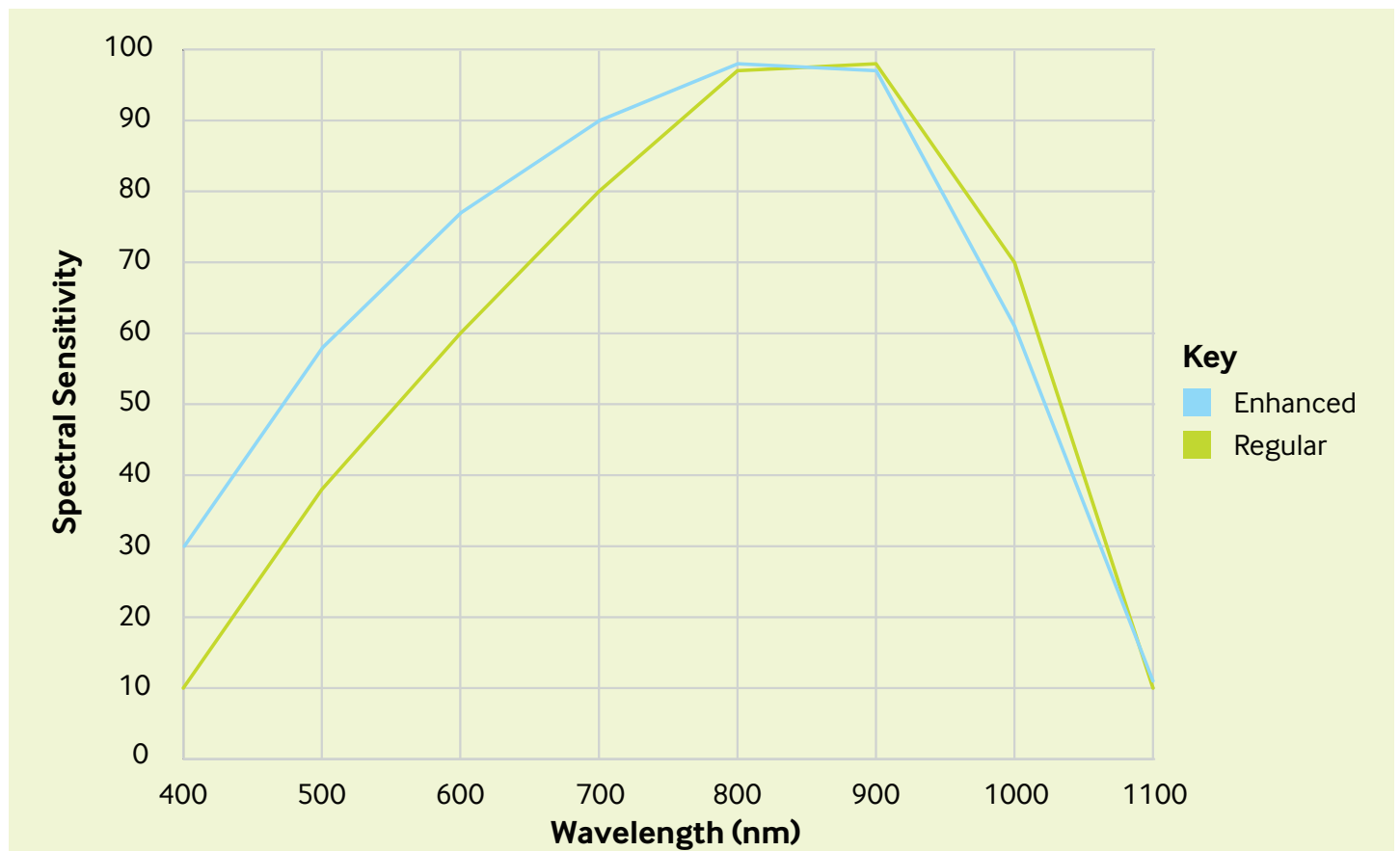

Specifications

	Standard	High Gain	High Frequency	Units	Notes
Electrical Characteristics					
Input & Output Leads (Pin Connections)	4 Leads, / Red (+Ve) / Black (0V) / Yellow (AC Out) / Blue (DC Out)				
Supply Voltage	+5	+10	+5	Vdc	
Operating Current	1 (No input signal) <25 (Maximum input Signal)			mA	
Connector Type	JST 4 Pin				
Reserve Polarity Protection	Yes				
Electrical Information					
AC Output Sensitivity (Q650nm)	1	10	1	V/mW	See Note 1
DC Output Sensitivity (Q650nm)	1			V/mW	See Note 2
AC Output to f_{limit} Response	1 to 680	1 to >100	10 to 660	kHz	See Note 3
DC Output to f_{reject} Response	0 to 1	0 to 1	0 to 10	kHz	See Note 3
Relative Ambient Light Rejection	20	10	20	db	
Linearity	5			%	
AC Signal to Noise Ratio	>60			db	See Note 4
DC Signal to Noise Ratio	>60			db	See Note 5
Input Acceptance Angle	60 (typ)			Degrees	
AC & DC Channel Impedance	50			Ohms	
Mechanical Information					
Dimensions	Ø15 x 51 (14mm of M12x1 Thread)			mm	
Weight	50			grams	
Housing	Anodized Aluminium				
Isolated Body	Yes				
Environmental Information					
Operating Case Temperature	-10 to +70			°C	
Storage Temperature	-10 to +85			°C	
Operating Humidity	90 (non condensing)			%RH	
NOTES					
All specifications are typical @ 25°C					
Note 1 - AC output is DC coupled, non-inverting and sits at mid rail					
Note 2 - DC output is measured relative to 0V (ground)					
Note 3 - f_{reject} and f_{limit} are the frequencies which DC and AC outputs are -3dB					
Note 4 - For 1mW peak to peak input signal					
Note 5 - For 1mW input signal					

Input Acceptance Angle

The graph below shows the PD signal amplitude variation with input angle of incidence (AOI), where an AOI of 0° means that the beam is aligned with the Hawkeye body length and at 90° the beam is perpendicular to the Hawkeye body length. This data was measured using a collimated Premier 650nm C2 (Ø2 mm collimated beam). The AOI at which the signal starts to drop (approx. 30° in the graph below) may vary with different beam parameters e.g. larger beam diameter, divergent/convergent beam.

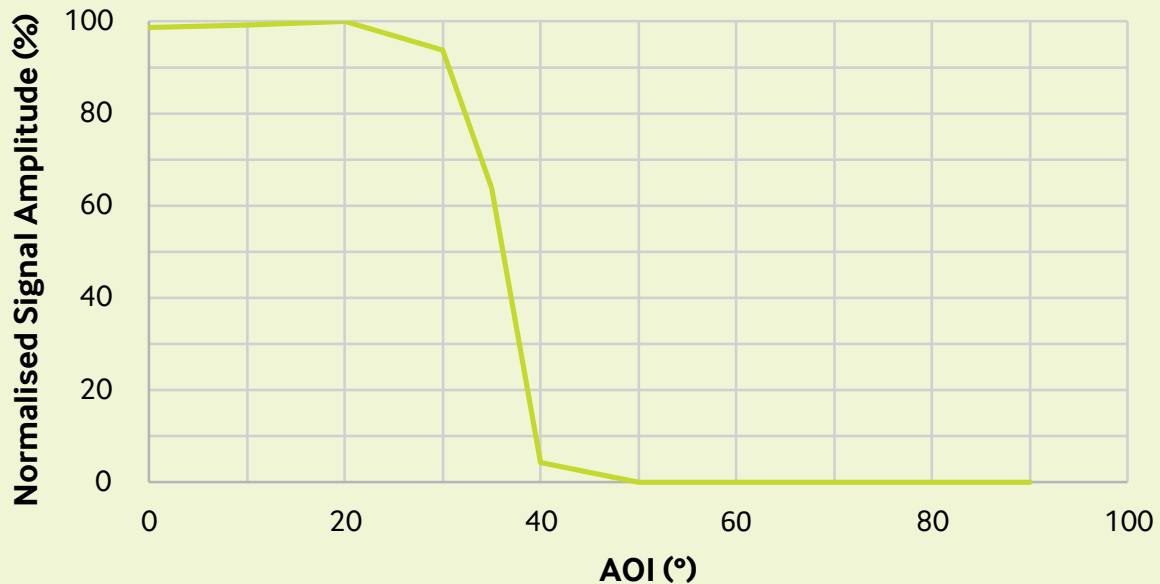

Mounting Options

Mounting Clamps

The heavy duty mounting clamp allows the Hawkeye to be securely fixed at any required direction or angle. The base plate has a series of threaded holes which allows the clamp to be fixed directly onto a machine or workbench. An optional magnetic base is also available.

The pillow block bearing mount contains a spherical rolling element that serves as a rotational bearing. Enables quick adjustment of the direction in one quick and easy movement without the need for an Allen key. The bearing also provides enough friction to keep the pointing direction stable.

The swivel clamp provides 180° tilt movement and $\pm 45^\circ$ swivel. Its base has a series of holes that allow the swivel clamp to be fixed directly onto a machine or workbench. For more information on any of these options please refer to the Accessories Datasheet.



Heavy Duty Mounting Clamp



Magnetic Mounting Base

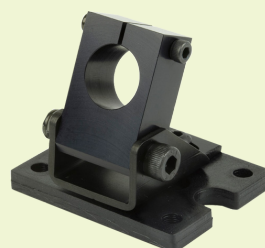

Adjustable Swivel Clamp



Pillow Block Bearing Mount

Mechanical Dimensions

Hawkeye Detector

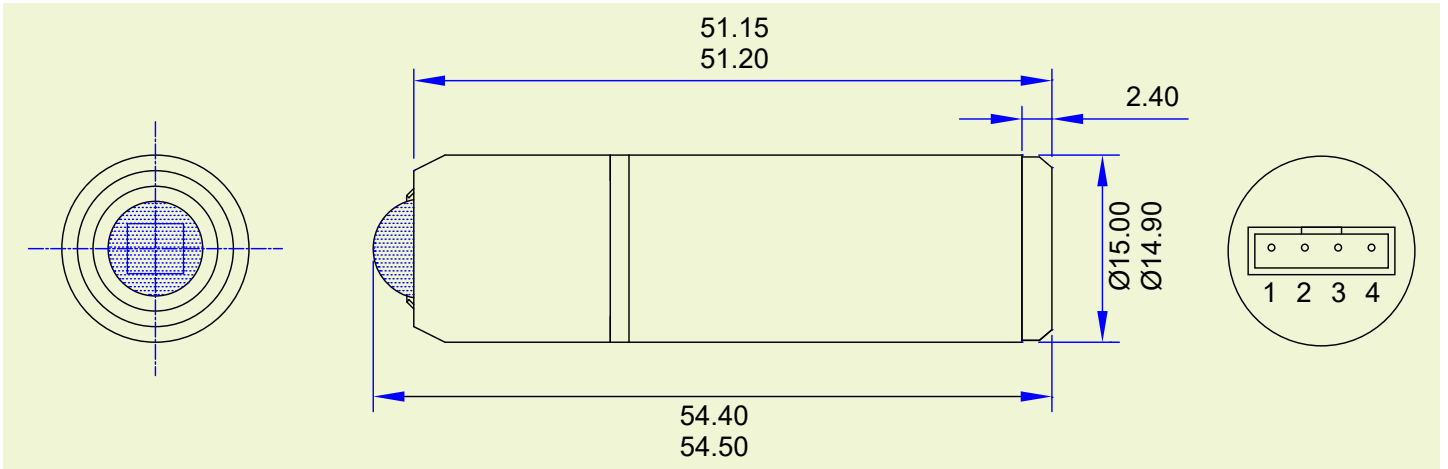

Hawkeye Detector without Front Sleeve

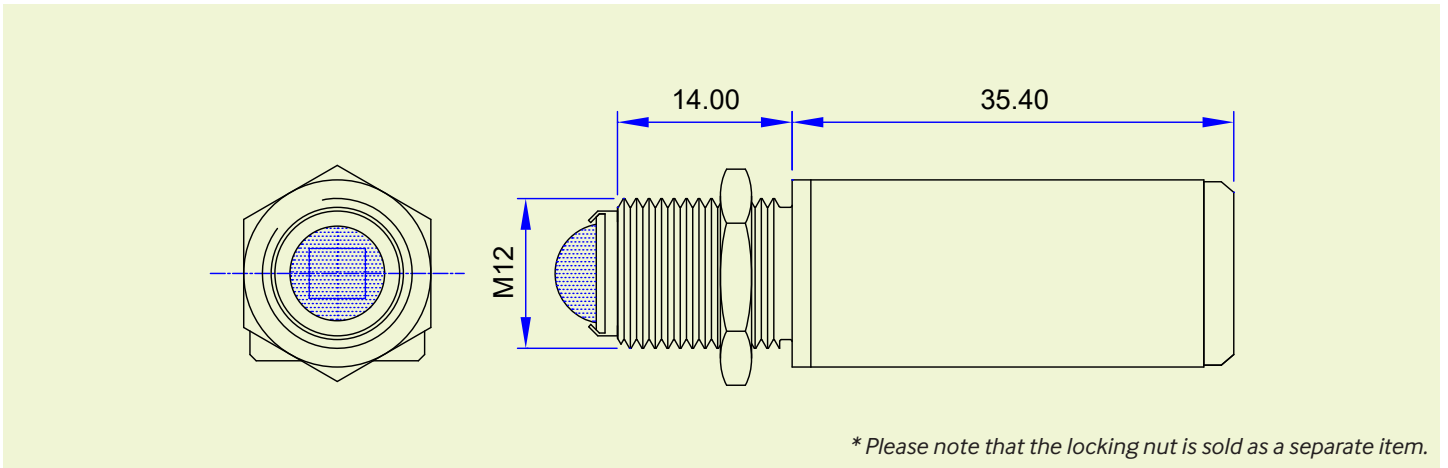

Sensitivity Area

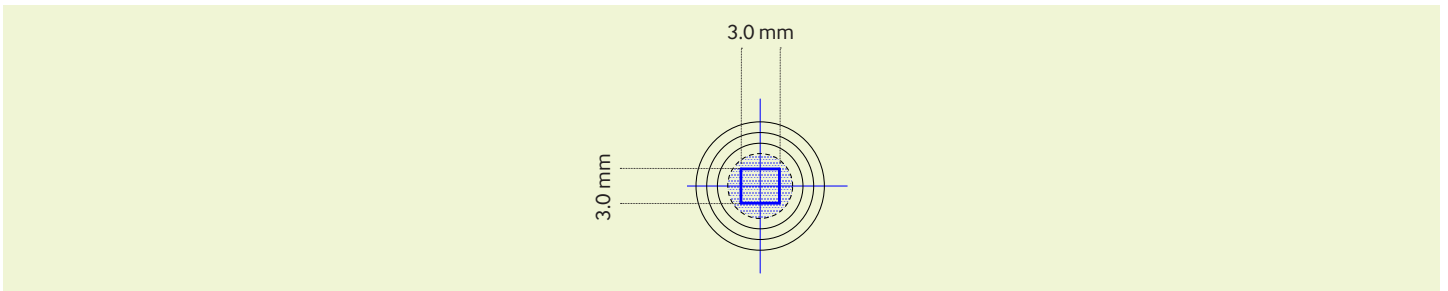

Please Note: Global Laser reserve the right to change descriptions and specifications without notice.



T: +44 (0)1495 212213
F: +44 (0)1495 214004
E: sales@globalasertech.com
www.globalasertech.com

Global Laser Ltd
Unit 9-10
Roseheyworth Business Park
Abertillery, Gwent, NP13 1SP, UK